



## Marley Building Materials Ltd

Station Road  
Coleshill  
Birmingham B46 1HP  
Tel: 01675 462081 Fax: 01675 465445  
e-mail: roofingsales@mbm-marley.co.uk  
website: www.marleyroofing.co.uk

**Agrément  
Certificate  
No 93/2909**  
Third issue\*

Designated by Government  
to issue  
European Technical  
Approvals

## MARLEY GRP VALLEY TROUGH FLASHINGS

Produit d'étanchéité pour toitures — PRV  
Dachabdichtungen — GFX

## Product



• THIS CERTIFICATE RELATES TO MARLEY GRP VALLEY TROUGH FLASHINGS.

• Each product is for use in slated or tiled roofs constructed in accordance with the relevant requirements of BS 5534 : 2003.

• The products are for use to direct or channel water away from, and provide a weatherproof junction, at changes of direction or materials.

These Front Sheets must be read in conjunction with the relevant accompanying Detail Sheets, which provide information specific to particular products.

## Regulations — Detail Sheet 1

### 1 The Building Regulations 2000 (as amended) (England and Wales)



The Secretary of State has agreed with the British Board of Agrément the aspects of performance to be used by the BBA in assessing the compliance of roof waterproofing systems with the Building Regulations. In the opinion of the BBA, Marley GRP Valley Trough Flashings, if used in accordance with the provisions of this Certificate, will meet or contribute to meeting the relevant requirements.

Requirement: B4(2)

External fire spread

Comment:

When tested to BS 476-3 : 1958, samples of GRP, representative of that used in the manufacture of the products, achieved an EXT.S.AB rating. See section 9 of these Front Sheets.

Requirement: C4

Resistance to weather and ground moisture

Comment:

Tests for water resistance on the products indicate that the flashings meet this Requirement. See section 8 of these Front Sheets.

Requirement: Regulation 7

Materials and workmanship

Comment:

The products are acceptable materials. See section 11 of these Front Sheets.

# Electronic Copy

## 2 The Building Standards (Scotland) Regulations 1990 (as amended)



In the opinion of the BBA, Marley GRP Valley Trough Flashings, if used in accordance with the provisions of this Certificate, will satisfy or contribute to satisfying the various Regulations and related Technical Standards as listed below.

Regulation:	10	Fitness of materials and workmanship
Standard:	B2.1	Selection and use of materials, fittings, and components, and workmanship
Comment:		The products can contribute to a construction meeting this Standard. See the <i>Installation</i> part of the relevant Detail Sheet.
Standard:	B2.2	Selection and use of materials, fittings, and components, and workmanship
Comment:		The products are acceptable materials. See section 11 of these Front Sheets.
Regulation:	12	Structural fire precautions
Standard:	D9.1	Fire spread from an adjoining building
Comment:		When tested to BS 476-3 : 1958 samples of GRP, representative of that used in the manufacture of the products, achieved an EXT.S.AB rating. This Standard imposes no restrictions upon the use of these products. See section 9 of these Front Sheets.
Regulation:	17	Resistance to moisture
Standard:	G3.1	Resistance to precipitation — Resistance to precipitation
Comment:		Tests for water resistance of the products indicate that the use of the products can contribute towards enabling a roof to satisfy the requirements of this Standard. See section 8 of these Front Sheets.

## 3 The Building Regulations (Northern Ireland) 2000



In the opinion of the BBA, Marley GRP Valley Trough Flashings, if used in accordance with the provisions of this Certificate, will satisfy or contribute to satisfying the various Building Regulations as listed below.

Regulation:	B2	Fitness of materials and workmanship
Comment:		The products are acceptable materials. See section 11 of these Front Sheets.
Regulation:	C4	Resistance to ground moisture and weather
Comment:		Tests for water resistance indicate that the use of the products can contribute towards enabling a roof to satisfy the requirements of this Regulation. See section 8 of these Front Sheets.
Regulation:	E5	External fire spread
Comment:		When tested to BS 476-3 : 1958 samples of GRP, representative of that used in the manufacture of the products, achieved an EXT.S.AB rating. This Regulation imposes no restrictions upon the use of the products. See section 9 of these Front Sheets.

## 4 Construction (Design and Management) Regulations 1994 (as amended) Construction (Design and Management) Regulations (Northern Ireland) 1995 (as amended)

Information in this Certificate may assist the client, planning supervisor, designer and contractors to address their obligations under these Regulations.

See section: 1 *Description* (1.2) of the relevant Detail Sheets.

## Technical Specification

### 5 Delivery and site handling

Marley GRP Valley Trough Flashings are delivered to site in the appropriate quantities. Each item bears the BBA identification mark incorporating the number of this Certificate. Packs should be stored flat on a clean, level surface.

## Design Data

### 6 General

6.1 Marley GRP Valley Trough Flashings are satisfactory for use on tiled or slated roofs constructed in accordance with the relevant requirements of BS 5534 : 2003.

6.2 The products should be cut to size with a fine-toothed saw and can accept holes being drilled using a sharp drill.

### 7 Strength

The products have adequate strength to resist impacts likely to occur during installation and use.

### 8 Weathertightness

 Data confirm that the products will adequately resist the passage of moisture to the inside of the building and so meet or comply with the relevant requirements of the national Building Regulations thus:

#### **England and Wales**

Approved Document C, Requirement C4, Section 5.1

#### **Scotland**

Regulation 17, Standard G3.1

#### **Northern Ireland**

Regulation C4.

### 9 Properties in relation to fire



Samples of GRP, representative of that used in the manufacture of the products, when tested in accordance with BS 476-3 : 1958, achieved an EXT.S.AB rating.

### 10 Maintenance

Minimum maintenance is required and the smooth surface finish will inhibit the build-up of foreign matter. Damaged lengths can be replaced without having to remove adjacent lengths.

### 11 Durability



Available test data and knowledge of the material indicate that the products should have a life of at least 20 years.

## Bibliography

BS 476-3 : 1958 *Fire tests on building materials and structures — External fire exposure roof test*

BS 5534 : 2003 *Code of practice for slating and tiling (including shingles)*

## Conditions of Certification

### 12 Conditions

12.1 This Certificate:

- (a) relates only to the product that is described, installed, used and maintained as set out in this Certificate;
- (b) is granted only to the company, firm or person identified on the front cover — no other company, firm or person may hold or claim any entitlement to this Certificate;
- (c) is valid only within the UK;
- (d) has to be read, considered and used as a whole document — it may be misleading and will be incomplete to be selective;
- (e) is copyright of the BBA;
- (f) is subject to English law.

12.2 References in this Certificate to any Act of Parliament, Regulation made thereunder, Directive or Regulation of the European Union, Statutory Instrument, Code of Practice, British Standard, manufacturers' instructions or similar publication, are references to such publication in the form in which it was current at the date of this Certificate.

12.3 This Certificate will remain valid for an unlimited period provided that the product and the manufacture and/or fabrication including all related and relevant processes thereof:

- (a) are maintained at or above the levels which have been assessed and found to be satisfactory by the BBA;

(b) continue to be checked by the BBA or its agents; and

(c) are reviewed by the BBA as and when it considers appropriate.

12.4 In granting this Certificate, the BBA is not responsible for:

- (a) the presence or absence of any patent or similar rights subsisting in the product or any other product;
- (b) the right of the Certificate holder to market, supply, install or maintain the product; and
- (c) the nature or standard of individual installations of the product or any maintenance thereto, including methods and workmanship.

12.5 Any recommendations relating to the use or installation of this product which are contained or referred to in this Certificate are the minimum standards required to be met when the product is used. They do not purport in any way to restate the requirements of the Health & Safety at Work etc Act 1974, or of any other statutory, common law or other duty which may exist at the date of this Certificate or in the future; nor is conformity with such recommendations to be taken as satisfying the requirements of the 1974 Act or of any present or future statutory, common law or other duty of care. In granting this Certificate, the BBA does not accept responsibility to any person or body for any loss or damage, including personal injury, arising as a direct or indirect result of the installation and use of this product.



In the opinion of the British Board of Agrément, Marley GRP Valley Trough Flashings are fit for their intended use provided they are installed, used and maintained as set out in this Certificate. Certificate No 93/2909 is accordingly awarded to Marley Building Materials Ltd.

On behalf of the British Board of Agrément

Date of Third issue: 5th December 2003

Chief Executive

*\*Original Certificate issued 4th May 1993. This version issued to include references to the revised national Building Regulations, CDM Regulations and Standards, and new Conditions of Certification.*



Marley Building Materials Ltd

Certificate No 93/2909

**MARLEY GRP VALLEY TROUGH FOR INTERLOCKING TILED ROOFS**

**DETAIL SHEET 2**  
Third issue\*

## Product

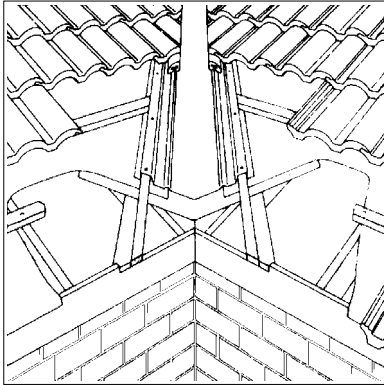

- THIS DETAIL SHEET RELATES TO THE MARLEY GRP VALLEY TROUGH FOR USE ON TILED ROOFS USING INTERLOCKING TILES ONLY.
- Tiled roofs must be constructed in accordance with the relevant requirements of BS 5534 : 2003.

*This Detail Sheet must be read in conjunction with the Front Sheets, which give Conditions of Certification and the product's position regarding the Building Regulations.*

## Technical Specification

### 1 Description

1.1 The Marley GRP Valley Trough For Interlocking Tiled Roofs (product code 30577) is manufactured from glass-fibre/polyester laminate in a continuous process to the profile illustrated (see Figure 1). Mortar bonding strips are provided along the upper surface of each edge, at the positions shown, to provide a key for bedding the roof tiles in mortar.

Figure 1 Valley trough profile

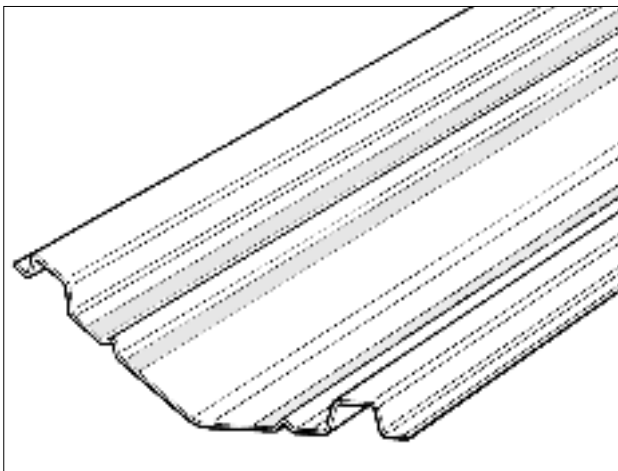

1.2 The profile is supplied in 3 metre lengths and is produced with a pitch of 21° but can be adapted by bending to accommodate roof pitches from 22.5° to 45°.

1.3 The product is finished in the standard colour lead grey with a laminated film on the upper surface giving a gloss finish which improves the weather resistance of the GRP.

1.4 Quality control of the product includes visual inspection and checks on weight and dimensions.

## Installation

### 2 General

Installation of the Marley GRP Valley Trough For Interlocking Tiled Roofs should be in accordance with the Certificate holder's instructions, the product label, and the relevant recommendations of BS 5534 : 2003, BS 8000-6 : 1990 and NFRC Technical Bulletin 28.

### 3 Procedure

3.1 Installation should be carried out prior to application of the tile battens.

3.2 Valley boards should be used and be lined longitudinally with reinforced underlay one metre wide. Counter battens of similar size to those to be used for the tiling battens should be fixed on both sides, along the length of the valley. The profiled valley trough should be fitted over the battens and nailed into place (see Figure 2). The valley trough can be bent to fit a range of pitch angles (see section 1.2).

Figure 2 Installation details

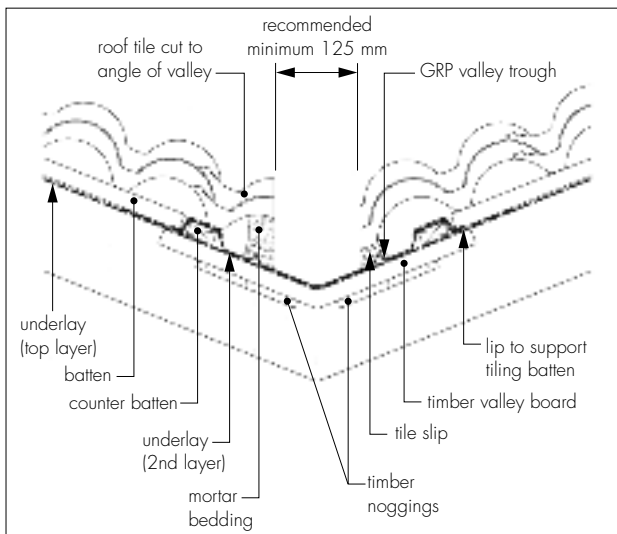

3.3 Commencing at the foot, the valley trough should be nailed to the counter battens through drilled holes prior to installation at 500 mm centres using nails of a quality acceptable in good roofing practice.

3.4 Consecutive lengths of valley trough should be laid with a minimum 150 mm overlap at the joints, when measured vertically, and fixed with two aluminium nails per side, finally trimming the head and foot of the valley using a fine-toothed saw.

3.5 The tiling battens are fixed and cut to the angle of the valley trough, the ends supported by the projecting lips.

3.6 The tiles are laid and then cut to the rake of the valley, leaving a minimum 125 mm central channel. The cut tiles are bedded in mortar applied over the sanded strip provided for keying and then neatly pointed. With deep profiled interlocking tiles, tile slips are used to reduce the risk of mortar shrinkage.

## Technical Investigations

The following is a summary of the technical investigations carried out on the Marley GRP Valley Trough For Interlocking Tiled Roofs.

### 4 Tests

Tests were carried out to examine the following properties:

- density
- glass/resin ratio
- cross-breaking strength
- hardness
- effect of elevation of temperature
- effect of water

### 5 Investigations

5.1 An assessment was made of the results of existing fire tests in accordance with BS 476-3 : 1958, carried out by an independent test authority.

5.2 The manufacturing process was examined, including the methods adopted for quality control, and details were obtained of the quality and composition of the materials used.

## Bibliography

BS 476-3 : 1958 *Fire tests on building materials and structures — External fire exposure roof test*

BS 5534 : 2003 *Code of practice for slating and tiling (including shingles)*

BS 8000-6 : 1990 *Workmanship on building sites — Code of practice for slating and tiling of roofs and claddings*



On behalf of the British Board of Agrément

Date of Third issue: 5th December 2003

Chief Executive

*\*Original Detail Sheet issued 4th May 1993. This revised version includes change to Technical Specification and Installation information, and reference to revised Standards.*



Marley Building Materials Ltd

Certificate No 93/2909

**MARLEY STANDARD GRP VALLEY TROUGH FOR TILED ROOFS**

**DETAIL SHEET 3**  
Second issue\*

## Product

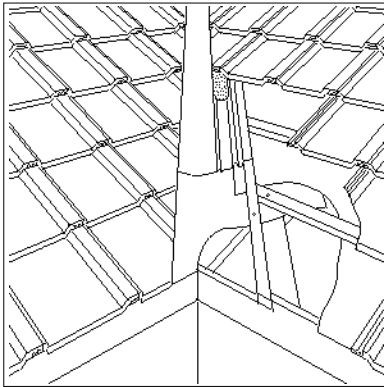

- THIS DETAIL SHEET RELATES TO THE MARLEY STANDARD GRP VALLEY TROUGH FOR USE ON TILED ROOFS.
- Tiled roofs must be constructed in accordance with the relevant requirements of BS 5534 : 2003.

This Detail Sheet must be read in conjunction with the Front Sheets, which give the product's position regarding the Building Regulations, general information relating to the product, and the Conditions of Certification.

## Technical Specification

### 1 Description

1.1 The Marley Standard GRP Valley Trough For Tile Roofs (product code 30579) is manufactured from glass-fibre/polyester laminates in a continuous process to the profile illustrated (see Figure 1). Mortar bonding strips are provided along the upper surface of each edge at the positions shown, to provide a key for bedding the roof tiles in mortar.

Figure 1 Marley Standard Valley Trough

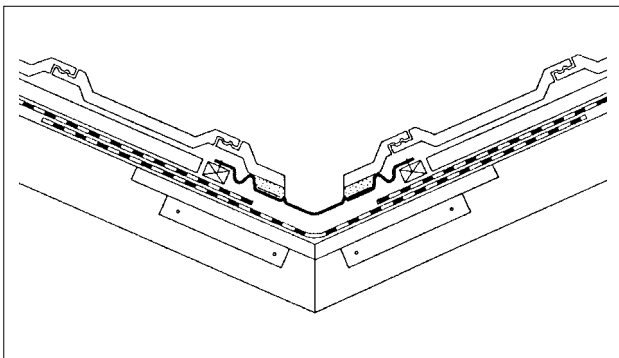

1.2 The product is available in a width of 360 mm and a length of 3 metres. It is produced with a pitch of 17.5° but can be adapted by bending to accommodate roof pitches from 22.5° to 60°.

1.3 The trough is finished in the standard colour of lead grey with a laminated film on the upper surface giving a gloss finish which improves the weather resistance of the GRP.

1.4 Quality control of the product includes visual inspection and checks on weight and dimensions.

## Installation

### 2 General

Installation of the Marley Standard GRP Valley Trough For Tiled Roofs should be in accordance with the Certificate holder's instructions, the product label and the relevant recommendations of BS 5534 : 2003, BS 8000-6 : 1990, and NFRC Technical Bulletin 28.

### 3 Procedure

3.1 The valley trough should be fixed onto counter battens or onto either new or existing valley boards. It is recommended that valley boards are used for all valley details comprising either 6 mm continuous ply boards laid over the rafters, or 12 mm ply (19 mm softwood) set between the rafters and supported on timber noggings or bearers.

3.2 The valley should first be lined longitudinally with a BS 747 : 2000, Type 1F or BBA approved roofing underlay for the width of the valley boards. The pitch angle of the valley trough, originally 17.5°, will adapt to suit pitches from 22.5° to 60°.

3.3 When using valley boards, a length of the trough should be firmly pressed down on to the valley board to support its base. The trough should be nailed, through pre-drilled holes at a maximum of 500 mm centres, to the valley boards using nails of a quality acceptable in good roofing practice.

3.4 The roof tile underlay should be laid and dressed over the counter batten. Roofing battens should be fitted with the ends firmly located onto the valley boards, positioned close to the counter batten with care taken to avoid damaging the underlay. The roof tile underlay can then be laid

# Electronic Copy

either under or over the GRP valley trough. If laid over the valley trough, it should not extend beyond the outer water channel.

3.5 The fascia board should be cut to allow the GRP valley trough to pass through and discharge into the gutter without flattening out. The end of the valley trough should be trimmed using a fine-toothed hacksaw to the approximate centre line of the gutter. Alternatively, a soaker of minimum Code 4 lead may be fitted and dressed into the gutter. The GRP valley troughs should then be fitted, starting at the foot of the valley, with care taken to ensure that they are located centrally on the valley boards before nailing the sides into the counter battens at 500 mm centres maximum and allowing a 150 mm minimum overlap when measured vertically.

3.6 At the head of the valley, a lead saddle (minimum Code 4) of sufficient length should be fixed to lap over the valley trough by the same length of lap required between the two GRP valley trough units.

3.7 At dormers, a lead soaker should be used at the base of the valley to dress onto the adjacent tiling. At sprocketed eaves or mansards, separate lengths of GRP valley trough should be fitted above and below with a lead saddle of sufficient lap length used to link the two parts.

3.8 The tiles should then be laid dry, the cut line marked and the tiles removed before cutting. They can be then re-laid in position, bedded onto mortar on the bonding strip with care taken to ensure no blockage of the water channels behind the bedding line occurs.

## Technical Investigations

The following is a summary of the technical investigations carried out on the Marley Standard GRP Valley Trough For Tiled Roofs.

## 4 Tests

Tests were carried out in accordance with MOAT No 9 : 1973 to determine:

- impact resistance
- density
- glass/resin ratio
- cross-breaking strength
- hardness
- effect of elevation temperature
- effect of water.

## 5 Investigations

5.1 The results of fire tests in accordance with BS 476-3 : 1958, carried out by an independent test authority, were assessed.

5.2 The manufacturing process was examined, including the methods adopted for quality control, and details were obtained of the quality and composition of the materials used.

5.3 Visits were made to sites in progress to assess the practicability of installation.

5.4 A survey of users was carried out to assess performance in use.

## Bibliography

BS 476-3 : 1958 *Fire tests on building materials and structures — External fire exposure roof test*

BS 747 : 2000 *Reinforced bitumen sheets for roofing — Specification*

BS 5534 : 2003 *Code of practice for slating and tiling (including shingles)*

BS 8000-6 : 1990 *Workmanship on building sites — Code of practice for slating and tiling of roofs and claddings*

MOAT No 9 : 1973 *Directive for the Assessment of Products in Glass-Reinforced Polyester for use in Building*



On behalf of the British Board of Agrément

A handwritten signature in black ink, appearing to read 'P. Q. Newson'.

Date of Second issue: 5th December 2003

Chief Executive

*\*Original Detail Sheet issued 14th October 1999. This amended Detail Sheet includes revised Technical Specification and Installation information, and reference to revised Standards.*

British Board of Agrément

P O Box No 195, Bucknalls Lane  
Garston, Watford, Herts WD25 9BA

Fax: 01923 665301

©2003

e-mail: mail@bba.star.co.uk  
website: www.bbacerts.co.uk



For technical or additional information, contact the Certificate holder (see front page).  
For information about the Agrément Certificate, including validity and scope, tel: Hotline 01923 665400, or check the BBA website.



**Marley Building Materials Ltd**

**Certificate No 93/2909**

**MARLEY INTERLOCKING SLATE GRP VALLEY TROUGH FOR SLATED ROOFS**

**DETAIL SHEET 4**  
Second issue\*

## Product

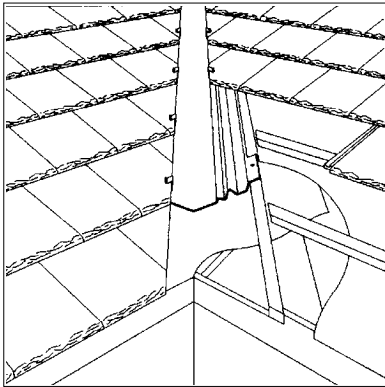

- THIS DETAIL SHEET RELATES TO THE MARLEY INTERLOCKING SLATE GRP VALLEY TROUGH FOR USE ON SLATED ROOFS.
- Slated roofs must be constructed in accordance with the relevant requirements of BS 5534 : 2003.

*This Detail Sheet must be read in conjunction with the Front Sheets, which give the product's position regarding the Building Regulations, general information relating to the product, and the Conditions of Certification.*

## Technical Specification

### 1 Description

1.1 The Marley Interlocking Slate GRP Valley Trough (product code 30578) is manufactured from a glass-fibre/polyester laminate in a continuous process to the profile illustrated (see Figure 1).

Figure 1 Marley Slate GRP Valley Trough

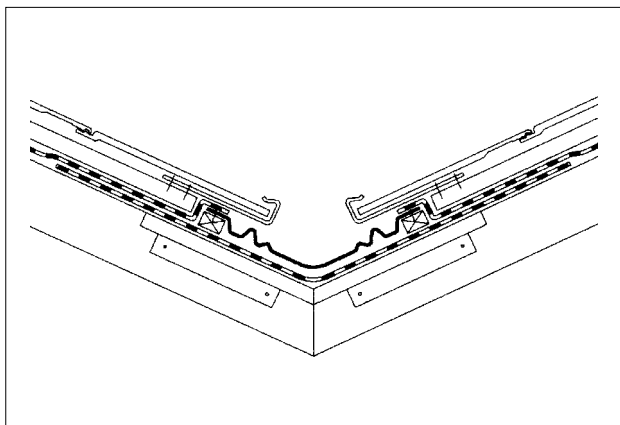

1.2 The profile is supplied in 3 metre lengths and is produced with a pitch of 17.5° but can be adapted by bending to accommodate roof pitches from 17.5° to 60°.

1.3 The product is finished in the standard colour of lead grey with a laminated film on the upper surface giving a gloss finish which improves the weather resistance of the GRP.

1.4 Quality control includes visual inspection and checks on weight and dimensions.

## Installation

### 2 General

Installation of the Marley Interlocking Slate GRP Valley Trough For Slated Roofs should be in accordance with the Certificate holder's instructions, the product label, and the relevant recommendations of BS 5534 : 2003, BS 8000-6 : 1990, and NFRC Technical Bulletin 28.

### 3 Procedure

3.1 The valley trough may be fixed directly onto counter battens either to existing or new valley boards. It is recommended that valley boards are used for all valley details, consisting either 6 mm continuous ply boards laid over rafters, or 12 mm ply (19 mm softwood) set between the rafters and supported on timber noggings or bearers.

3.2 The valley should first be lined longitudinally with a BS 747 : 2000, Type 1F or BBA approved underlay one metre wide. The pitch angle of the valley trough, originally 17.5°, will adapt to suit pitches from 17.5° to 60°.

3.3 Counter battens of the same depth as the tiling battens should be fitted onto the valley boards over the underlay at the appropriate distance from the valley centre to accommodate the GRP valley trough and nailed through into the main rafters/trusses below.

3.4 The lengths of the valley trough should be firmly pressed down on to the valley board to support the base. The valley troughs should be nailed, through pre-drilled holes at a maximum of 500 mm centres, to the counter batten using nails of a quality acceptable in good roofing practice.

3.5 The roof tile underlay should then be laid and dressed over the counter batten. Roofing battens should be fitted with the ends firmly located onto the valley boards, positioned close to the counter batten with care taken to avoid damaging the underlay. The roof tile underlay can then be laid either under or over the GRP valley trough. If laid over the valley trough, it should not extend beyond the outer water channel.

3.6 The fascia board should be cut to allow the GRP valley trough to pass through and discharge into the gutter without flattening out. The end of the valley trough should be trimmed using a fine-toothed hacksaw to the approximate centre line of the gutter. Alternatively, a soaker of minimum Code 4 lead may be fitted and dressed into the gutter. The GRP valley troughs should then be fitted, starting at the foot of the valley, with care taken to ensure that they are located centrally on the valley boards before nailing the sides into the counter battens at 500 mm centres maximum and allowing a 150 mm minimum overlap when measured vertically.

3.7 At the head of the valley, a lead saddle (minimum Code 4) of sufficient length should be fixed to lap over the valley trough by the same length of lap required between the two GRP valley trough units.

3.8 At dormers, a lead soaker should be used at the base of the valley to dress onto the adjacent tiling. At sprocketed eaves or mansards, separate lengths of GRP valley trough should be fitted above and below with a lead saddle of sufficient lap length used to link the two parts.

3.9 The slates should be installed in accordance with the manufacturer's instructions, allowing a 50 mm overhang into the valley trough.

The following is a summary of the technical investigations carried out on the Marley Interlocking Slate GRP Valley Trough For Slated Roofs.

#### 4 Tests

Tests were carried out in accordance with MOAT No 9 : 1973 to determine:

- impact resistance
- density
- glass/resin ratio
- cross-breaking strength
- hardness
- effect of elevation temperature
- effect of water.

#### 5 Investigations

5.1 The results of fire tests in accordance with BS 476-3 : 1958, carried out by an independent test authority, were assessed.

5.2 The manufacturing process was examined, including the methods adopted for quality control, and details were obtained of the quality and composition of the materials used.

## Bibliography

BS 476-3 : 1958 *Fire tests on building materials and structures — External fire exposure roof test*

BS 747 : 2000 *Reinforced bitumen sheets for roofing — Specification*

BS 5534 : 2003 *Code of practice for slating and tiling (including shingles)*

BS 8000-6 : 1990 *Workmanship on building sites — Code of practice for slating and tiling of roofs and claddings*

MOAT No 9 : 1973 *Directive for the Assessment of Products in Glass-Reinforced Polyester for use in Building*



On behalf of the British Board of Agrément

A handwritten signature in black ink, appearing to read 'P. Q. Newson'.

Date of Second issue: 5th December 2003

Chief Executive

\*Original Detail Sheet issued 14th October 1999. This amended Detail Sheet includes revised Technical Specification and Installation information, and reference to revised Standards.



Marley Building Materials Ltd

Certificate No 93/2909

**MARLEY GRP DRY TROUGH VALLEY FOR INTERLOCKING TILED ROOFS**

**DETAIL SHEET 5**  
Second issue\*

## Product

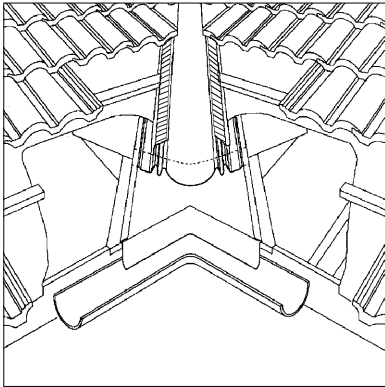

- THIS DETAIL SHEET RELATES TO THE MARLEY GRP DRY TROUGH VALLEY FOR USE ON TILED ROOFS.
- Tiled roofs must be constructed in accordance with the relevant requirements of BS 5534 : 2003.

This Detail Sheet must be read in conjunction with the Front Sheets, which give the product's position regarding the Building Regulations, general information relating to the product, and the Conditions of Certification.

## Technical Specification

### 1 Description

1.1 The Marley GRP Dry Trough Valley For Interlocking Tiled Roofs (code 30420) is manufactured from glass-fibre/polyester laminates in a continuous process to the profile illustrated (see Figure 1).

Figure 1 Marley Dry Trough Valley

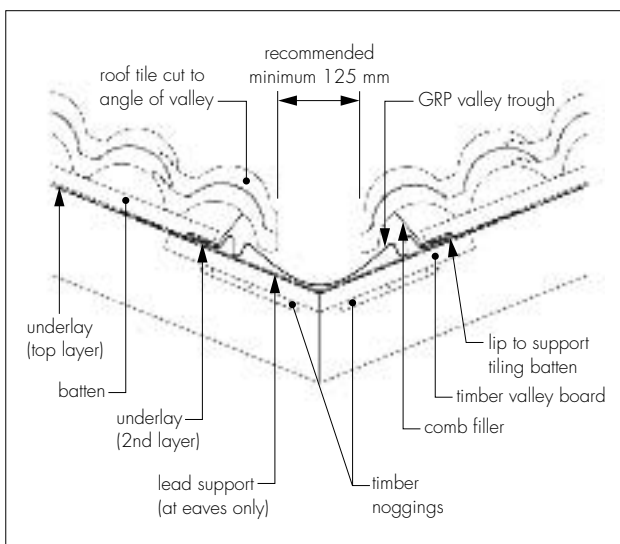

1.2 The product is available in a width of 625 mm and a length of 3 m. It is produced with a pitch of 12° but can be adapted by bending to accommodate roof pitches from 22.5° to 45°.

1.3 The trough is finished in the standard colour of lead grey with a laminated film on the upper surface giving a gloss finish which improves the weather resistance of the GRP.

1.4 An ancillary item available for use with the product is the Comb Filler Strip (code 30428 and 30425).

1.5 Quality control of the product includes visual inspection and checks on weight and dimensions.

## Installation

### 2 General

Installation of the Marley GRP Dry Trough Valley For Interlocking Tiles Roofs should be in accordance with the Certificate holder's instructions, the product label and the relevant recommendations of BS 5534 : 2003, BS 8000-6 : 1990, and NFRC Technical Bulletin 28.

### 3 Procedure

3.1 The dry trough valley may be fixed directly onto either existing or new valley boards in accordance with standard roofing practice.

3.2 The valley should first be lined longitudinally with a BS 747 : 2000, Type 1F or BBA approved underlay one metre wide. The pitch angle of the dry trough valley will adapt to suit pitches from 22.5° to 45°.

# Electronic Copy

3.3 The fascia board should be cut to allow the GRP valley trough to pass through and discharge into the gutter without flattening out. The end of the valley trough should be trimmed using a fine-toothed hacksaw to the approximate centre line of the gutter. Alternatively, a soaker of minimum Code 4 lead may be fitted and dressed into the gutter. The GRP valley troughs should then be fitted, starting at the foot of the valley.

3.4 The GRP dry valley trough should be fitted ensuring a minimum 150 mm overlap at the joints when measured vertically and fixed with two aluminium nails per side. Comb filler strips should be secured into the preformed grooves in the gutter section.

3.5 The underlay should run into the back of the comb filler strip to each slope.

3.6 The battens should be close cut onto the GRP moulding and secured using nails of a quality acceptable in good roofing practice.

3.7 Valley tiles should be laid, scribed and cut to provide a minimum 125 mm clear channel. To avoid unsecured small tile pieces, larger pieces of cut tile should be used to secure to an intermediate batten.

3.8 At the head of the valley, a lead saddle (minimum Code 4) of sufficient length should be fixed to lap over the valley trough by the same length of lap required between the two GRP valley trough units.

3.9 At dormers, a lead soaker should be used at the base of the valley to dress onto the adjacent tiling. At sprocketed eaves or mansards, separate lengths of GRP valley trough should be fitted above and below with a lead saddle of sufficient lap length used to link the two parts.

## Technical Investigations

The following is a summary of the technical investigations carried out on the Marley GRP Dry Trough Valley For Interlocking Tiled Roofs.

### 4 Tests

Tests were carried out in accordance with MOAT No 9 : 1973 to determine:

- impact resistance
- density
- glass/resin ratio
- cross-breaking strength
- hardness
- effect of elevation temperature
- effect of water.

### 5 Investigations

5.1 The results of fire tests in accordance with BS 476-3 : 1958, carried out by an independent test authority, were assessed.

5.2 The manufacturing process was examined, including the methods adopted for quality control, and details were obtained of the quality and composition of the materials used.

## Bibliography

BS 476-3 : 1958 *Fire tests on building materials and structures — External fire exposure roof test*

BS 747 : 2000 *Reinforced bitumen sheets for roofing — Specification*

BS 5534 : 2003 *Code of practice for slating and tiling (including shingles)*

BS 8000-6 : 1990 *Workmanship on building sites — Code of practice for slating and tiling of roofs and claddings*

MOAT No 9 : 1973 *UEAtc Directive for the Assessment of Glass-Reinforced Polyester for use in Building*



On behalf of the British Board of Agrément

A handwritten signature in black ink, appearing to read 'P. Q. Newson'.

Date of Second issue: 5th December 2003

Chief Executive

*\*Original Detail Sheet issued 8th March 2000. This amended version includes revised Technical Specification and Installation information, and reference to revised Standards.*

British Board of Agrément

P O Box No 195, Bucknalls Lane  
Garston, Watford, Herts WD25 9BA

Fax: 01923 665301

©2003

e-mail: mail@bba.star.co.uk  
website: www.bbacerts.co.uk



For technical or additional information, contact the Certificate holder (see front page).  
For information about the Agrément Certificate, including validity and scope, tel: Hotline 01923 665400, or check the BBA website.